

MOUNTING AND INSTRUCTION MANUAL

SEM 100 / SAM 100 / SEM 100 24h

MOBALine movement



Certification of the producer

STANDARDS

The movement SEM100 / SAM100 was developed and produced in accordance with the EU Guidelines:

2006 / 95 / EC
2004 / 108 / EC
96 / 48 / EC



References to the Instruction Manual

1. The information in this Instruction Manual can be changed at any time without notice. The current version is available for download on www.mobatime.com.
2. This Instruction Manual has been composed with the utmost care, in order to explain all details in respect of the operation of the product. Should you, nevertheless, have questions or discover errors in this Manual, please contact us.
3. We do not answer for direct or indirect damages, which could occur, when using this Manual.
4. Please read the instructions carefully and only start setting-up the product, after you have correctly understood all the information for the installation and operation.
5. The installation must only be carried out by skilled staff.
6. It is prohibited to reproduce, to store in a computer system or to transfer this publication in a way or another, even part of it. The copyright remains with all the rights with BÜRK MOBATIME GmbH, D-78026 VS-Schwenningen and MOSER-BAER AG – CH 3454 Sumiswald / SWITZERLAND.

Content

1. Safety.....	4
1.1 Safety instructions.....	4
1.2 Symbols and Signal Words used in this Instruction Manual.....	4
1.3 Intended Use.....	4
1.4 Observe operating safety!.....	4
1.5 Consider the installation site!.....	5
1.6 Please observe the electromagnetic compatibility!.....	5
2. Maintenance.....	6
2.1 Troubleshooting: Repairs.....	6
2.2 Cleaning.....	6
2.3 Disposing.....	6
3. General Information: Introduction.....	7
3.1 Scope of Delivery.....	7
3.2 Technical Data.....	7
3.3 Device Description in this Manual.....	7
3.4 Introduction.....	8
3.5 Device types.....	8
3.6 Measurements, definitions.....	9
4. Display and control elements.....	11
4.1 LED.....	11
4.2 Push-button functions.....	11
4.3 Menu layout (V01).....	12
4.4 Clock ID / ID mode.....	13
5. Mounting and start-up.....	14
5.1 Movement mounting.....	14
5.2 Mounting of hands and start-up.....	14
5.2.1 Mounting of hands.....	14
5.2.2 Start-up and checking the hand position.....	14
5.3 Basic settings (Factory settings).....	15
5.4 Time-keeping.....	15
6. Technical data.....	16

1. Safety



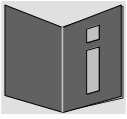

1.1 Safety instructions



Read this chapter and the entire instruction manual carefully and follow all instructions listed. This is your assurance for dependable operations and a long life of the device.

Keep this instruction manual in a safe place to have it handy every time you need it.

1.2 Symbols and Signal Words used in this Instruction Manual

	Danger! Please observe this safety message to avoid electrical shock! There is danger to life!
	Warning! Please observe this safety message to avoid bodily harm and injuries!
	Caution! Please observe this safety message to avoid damages to property and devices!
	Notice! Additional information for the use of the device.

1.3 Intended Use

The SEM100 (24h) / SAM100 is a MOBALine / DCF active movement for the use in outdoor clocks with diameter up to 1m. It can be synchronized via MOBALine as well as DCF active.

For additional functions, see the device descriptions in chapter 3.



Caution!

1.4 Observe operating safety!

- Never open the housing of the device! This could cause an electric short or even a fire, which would damage your device. Do not modify your device!
- The device is not intended for use by persons (including children) with limited physical, sensory, or mental capacities or a lack of experience and/or knowledge.
- Keep packaging such as plastic films away from children. There is the risk of suffocation if misused.

1.5 Consider the installation site!



Caution!

- To avoid any operating problems, keep the device away from moisture and avoid dust, heat, and direct sunlight. Do not use the device outdoors.
- The device is designed for the installation in a vertically mounted dial.



Danger! Make sure

that you wait before using the device after any transport until the device has reached the ambient air temperature. Great fluctuations in temperature or humidity may lead to moisture within the device caused by condensation, which can cause a short.

1.6 Please observe the electromagnetic compatibility!



Caution!

- This device complies with the requirements of the EMC and the Low-voltage Directive.

2. Maintenance

2.1 Troubleshooting: Repairs

If you cannot rectify the problems, contact your supplier from whom you have purchased the device.

Any repairs must be carried out at the manufacturer's plant.

Disconnect the power supply immediately and contact your supplier, if...

- liquid has entered your device
- the device does not properly work and you cannot rectify this problem yourself.

2.2 Cleaning

- Please make sure that the device remains clean especially in the area of the connections, the control elements, and the display elements.
- Clean your device with a damp cloth only.
- Do not use solvents, caustic, or gaseous cleaning substances.

2.3 Disposing



Device

At the end of its lifecycle, do not dispose of your device in the regular household rubbish. Return your device to your supplier who will dispose of it correctly.



Packaging

Your device is packaged to protect it from damages during transport.

Packaging is made of materials that can be disposed of in an environmentally friendly manner and properly recycled.

3. General Information: Introduction

3.1 Scope of Delivery

Please check your delivery for completeness and notify your supplier within 14 days upon receipt of the shipment, if it is incomplete.

The package you received contains:

- One SEM 100(t) or SAM 100(t) or SEM 100 24h
- Screw-type terminal connector 2-pole green for MOBALine/DCF active

3.2 Technical Data

See chapter „6 Technical data“.

3.3 Device Description in this Manual

This instruction manual is for the movements SEM 100, SEM 100t, SAM 100, SAM 100t and SEM 100 24h. In the following chapters, the designation **SEM 100** or **movement** is used for improved readability.

3.4 Introduction

The **SEM 100** is a self-setting movement with (24-hour,) hour, minute and second hand. It is synchronized and powered via MOBALine / DCF active signal. It can be used for outdoor and indoor clocks with a diameter of up to 100 cm.

Properties:

- MOBALine / DCF active controlled with automatic time take-over and daylight-saving time via connected MOBALine / DCF active master clock
- Signalization of the missing MOBALine time signal after 24 hours by setting the hands to 12 o'clock
- Signalization of the missing DCF active time signal after 7 days.
- Two motors: one for (24-hour /) hour / minute hand and one for second hand
- Push-button for configuration: Can change the second mode, but may be overwritten by the MOBALine signal.
- Running mode of the minute and second hand selectable via MOBALine signal (identical for all clocks of the same clock line).
- Fully powered by MOBALine / DCF active.

3.5 Device types

Model:	Features:	Product no.:
SEM 100	Movement for second, minute and hour hand	118171
SEM 100t	Movement for second, minute and hour hand	118172
SAM 100	Movement for minute and hour hand	118173
SAM 100t	Movement for minute and hour hand	118174
SEM 100 24h	Movement for second, minute, hour and 24-hour hand	131032

SEM 100 24h:

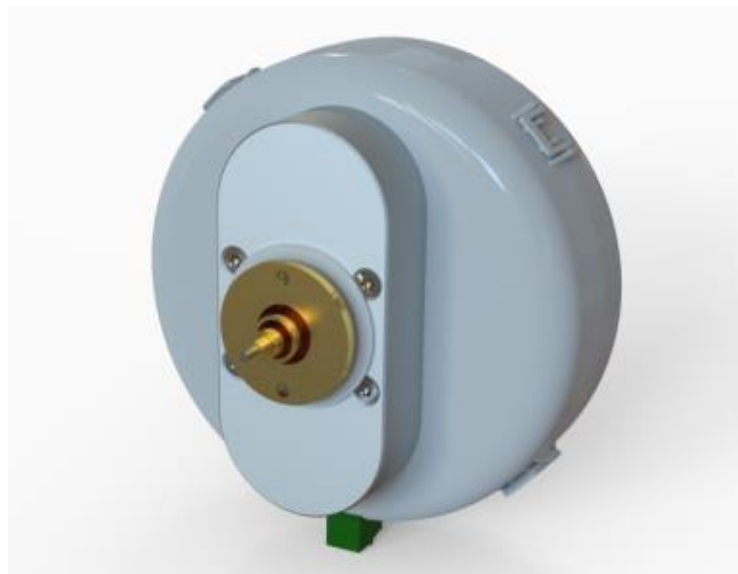

3.6 Measurements, definitions

Movements: SAM / SEM 100(t), SEM 100 24h	clock diameter:	30 - 100 cm
--	-----------------	-------------

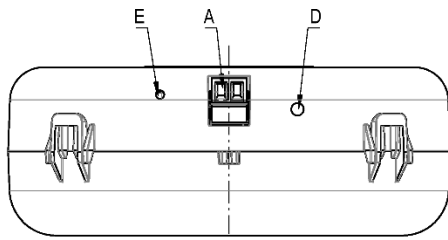

- A MOBALine connector
- B required space for connector
- C housing clips
- D push-button

- E LED
- F Disc nut for mounting
- G Rubber washer
- * Second shaft only for SEM 100(t)
- all dimensions in mm

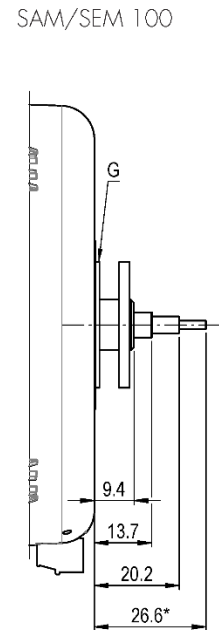
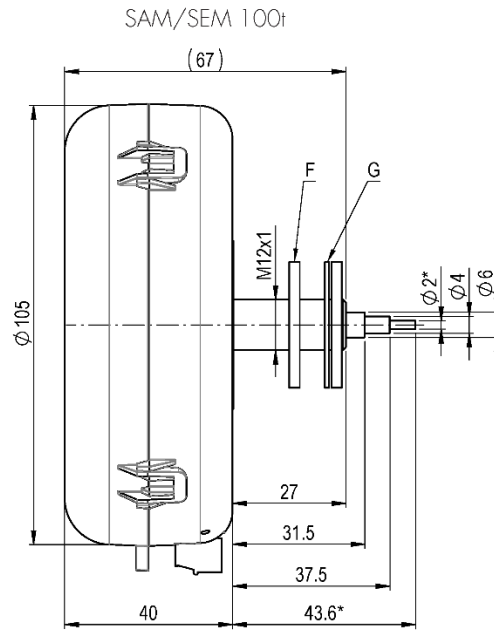
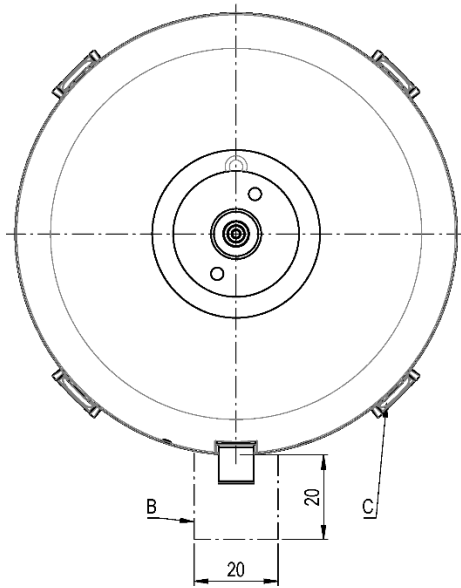

SEM 100 24h

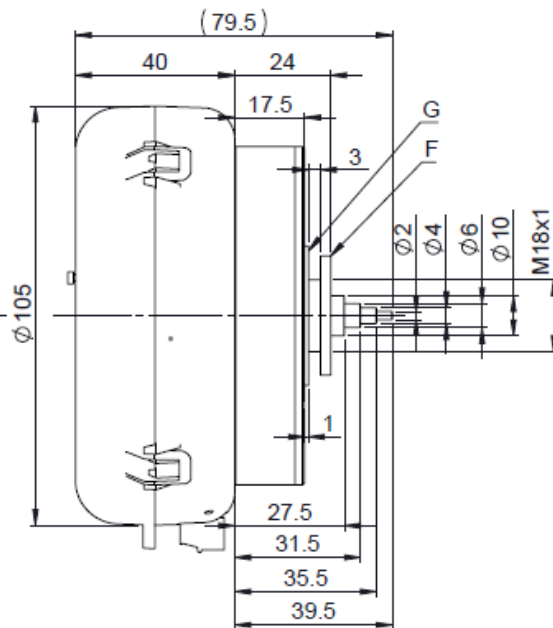
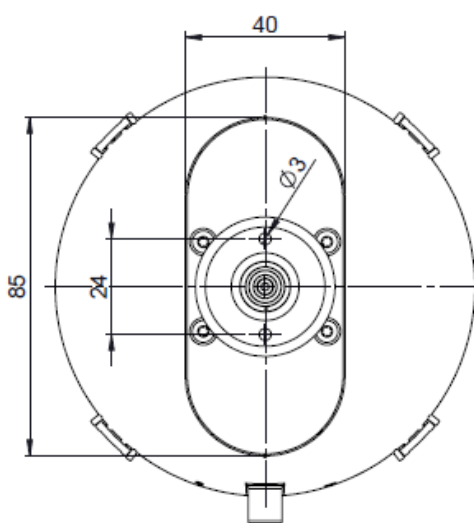

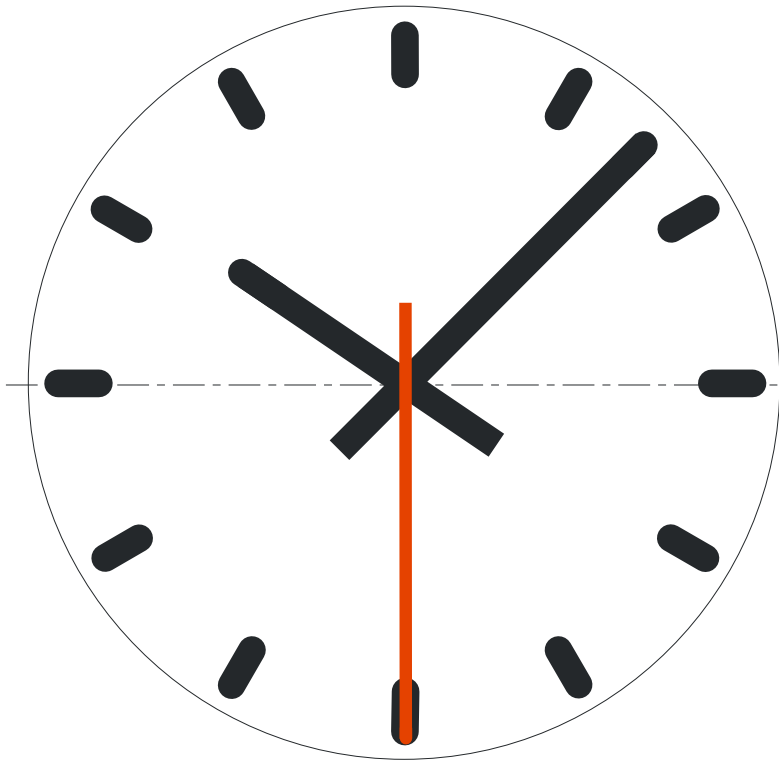

SEM 100t

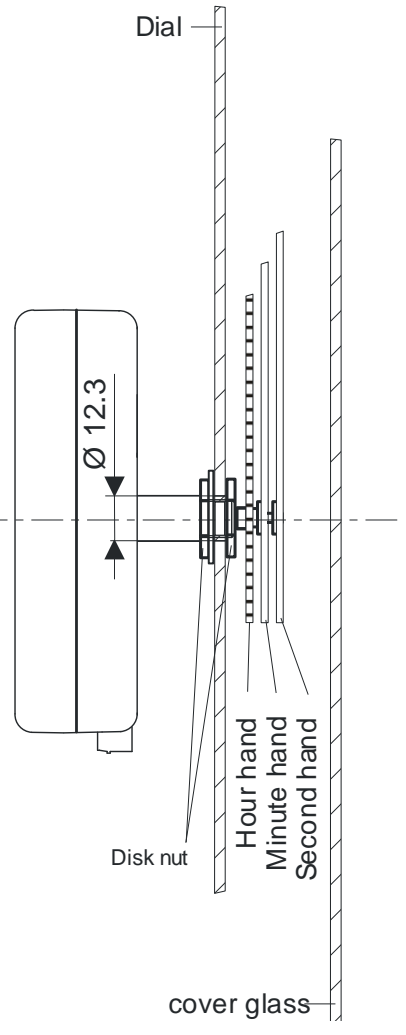

4. Display and control elements

The display and control possibilities of the movement depend on the device version. It can be determined from the article number printed onto the sticker on the rear side of the device (e.g. A/N: 118171.01 or 118171.02). Differences between the versions are noted.

4.1 LED

Version		Condition	Signal (duration: 2 seconds)
01	02		
✓	✓	Normal operation: LED continuously ON	████████████████████
		Setting mode:	
	✓	12:00 mode: LED 1s ON, 1s OFF (0.5 Hz)	██████████
	✓	Setting the minute hand: Minute mode	██████████ █
	✓	Setting the second hand: Second mode	██████████ █ █
	✓	Setting clock ID: ID mode	██████████ █ █ █
	✓	Factory settings: all settings cleared	██████████ █ █ █ █ █
		Error conditions:	
✓	✓	No power supply	
✓	✓	No synchronization*	█
✓	✓	Power supply error	█ █
✓	✓	Detection error second hand**	█ █ █
✓	✓	Detection error minute- and 24h-hand**	█ █ █ █
✓	✓	Internal error**	█ █ █ █ █
✓	✓	Test mode active	█ █ █ █ █ █

* Is also shown during establishment of the synchronization. With DCF, this process takes several minutes, with MOBALine approx. 5 seconds. A weak connection can cause the dial-up to take longer.

** Movement must be replaced.

The various menus are detailed below.

4.2 Push-button functions

V00/01

Push	Action
<1s	Change to next second mode (double-click: change to previous mode)
>4s	Switch between normal operation and 12:00 position
>15s	Movement is reset to factory settings

V02

Push	Normal operation	In menu
short (<1s)	-	In minute or second mode menu: Change to next minute/second mode (double-push: change to previous mode)
>1s	-	Change to next menu: 12:00 position → Minute mode → Second mode
>3s	Enter menu: run to 12:00 position	Switch to normal operation
>15s	Movement is reset to factory settings	

4.3 Menu layout (V02)

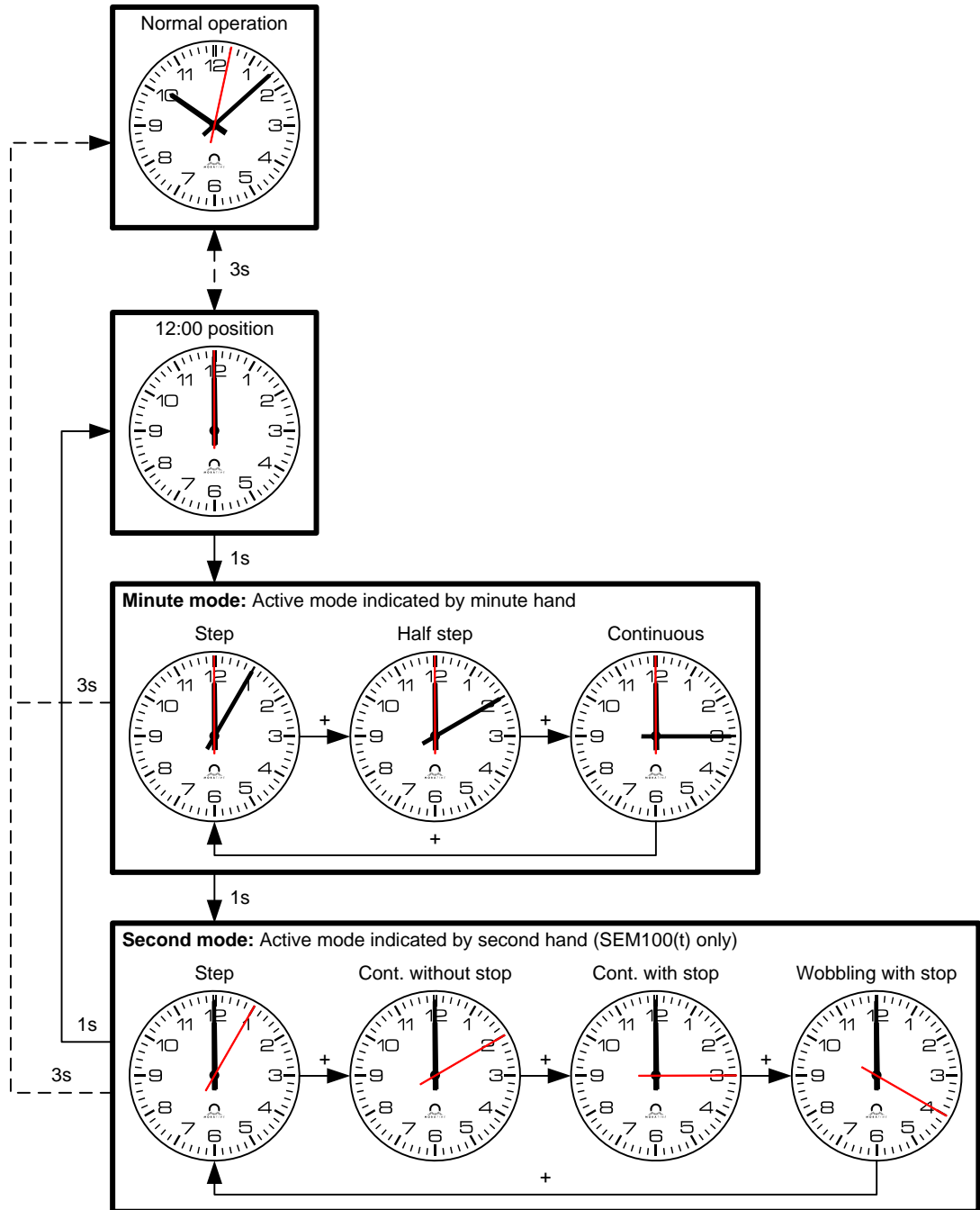

The current menu position/mode is indicated via the LED blinking pattern and hand positions.

After 5 minutes without entry (button push), the movement automatically goes into normal operation.

If the master clock dictates the minute resp. second hand mode, the manual mode settings will be overwritten.

4.4 Clock ID / ID mode

With MOBALine operation, it is possible to assign an ID between 1 and 12 to each clock. With this, the clock can be identified via NMS.

Using NMS, the clock can be set to ID mode. In this mode, the movement indicates the clock's current ID with the minute and (if available) second hand pointing at the corresponding hour. The controls for setting the ID are identical to those used when setting a hand mode.

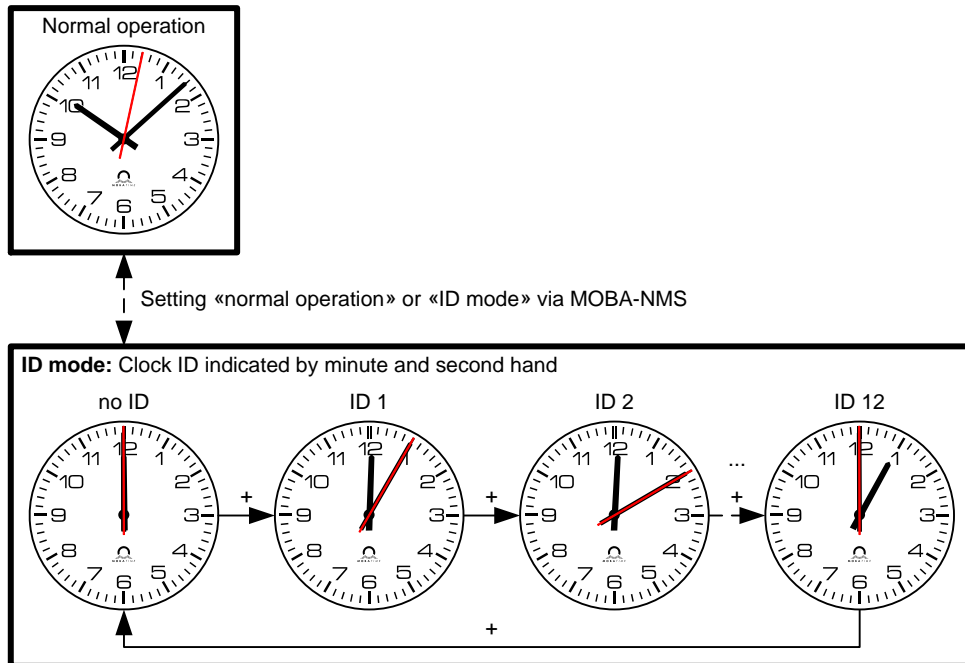

The movement can only be returned to normal operation using NMS.

For the direct switch from no ID to ID 12 (one double click), the minute hand has to complete one full rotation, which takes several seconds.

5. Mounting and start-up

5.1 Movement mounting

The dial must be adequately stable. The mounting drill hole must have a diameter of 12.3 mm (SEM 100 24h: 18.3 mm). The movement must be mounted in a vertical position.

The position of the mounting parts is shown in fig. 1. The disc nut (2*) M12 x 1 is to be carefully tightened with a special wrench tool (Art. no. 36761) and a torque wrench with a torque of 4.5 Nm +/- 0.2 Nm.

Attention:

After tightening of the disc nut (2*), the movement must not be moved anymore!

SEM 100 24h:
Disc nut (2*) M18 x 1

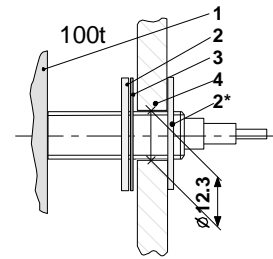

Fig. 1

- 1 Movement
- 2 Disc nut
- 3 Rubber washer
- 4 Dial

5.2 Mounting of hands and start-up

5.2.1 Mounting of hands

The shafts of the hour, minute and second hand are positioned ex-work on the 12 o'clock position. The hands are to be fixed and tightened on the shafts without rotating the shafts. Enough space must be provided between the hands. See Fig. 2.

For the mounting of the hands, the movement should be rested on a flat surface. The hands should be mounted without using too much force. Excessive pressure on the axis can damage the movement!

The 12 o'clock position must be checked on each movement after mounting the hands (chap. 5.2.2).

With 24h-hand the same distance X must be applied.

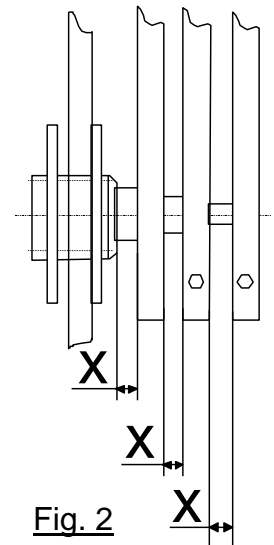

Fig. 2

5.2.2 Start-up and checking the hand position

- Connect time signal
- Hold down push-button for 5s (12 o'clock position)
→ Are the hands exactly on the 12 o'clock position?
- If the hand position is incorrect, carefully loosen the hand, adjust and then tighten it again (shaft must not be rotated during this).
- If the hand position is correct, hold down the push-button for 5s again. The clock is now ready for operation and sets itself.



Caution!

5.3 Basic settings (Factory settings)

Basic settings:

Second hand: continuous with stop

Minute hand: step mode

Basic settings:

Second hand: continuous without stop

Minute hand: continuous mode

5.4 Time-keeping

In case of loss of the MOBALine signal (only power supply without modulation available) the movement keeps running for 24h on quartz base and afterwards runs to the 12 o'clock position.

In case of loss of the DCF active signal (only power supply available) the clock keeps running for 7 days on quartz base and afterwards runs to the 12 o'clock position.

6. Technical data

	SAM 100(t)	SEM 100(t)	SEM 100 24h
Dial diameter	up to 1000 mm		
Synchronization	- MOBALine (local time) (ETC, DTS, NMI...) - DCF active bipolar		
Power supply	MOBALine or DCF active		
Consumption	SAM 100t < 20 mA (at >14 VAC)	SEM 100t < 30 mA (at >14 VAC)	
Operating mode hour shaft	Continuous		
Operating mode minute shaft	Minute, ½ minute or continuous (10 sec.) Setting via MOBALine		
Operating mode second shaft	-	Step-wise, continuous with/without stop, wobbling with stop Setting via push-button or via MOBALine (not supported by all master clocks)	
Setting time	Start-up: < 3 min. Daylight-saving time: < 30 sec.		< 6 min. < 30 sec.
Temperature range	-30 ... +70 °C		
Weight	SAM 100: 195 g SAM 100t: 210 g	SEM 100: 230 g SEM 100t: 250 g	400 g
Second shaft torque	-	>50 mNm	
Minute shaft torque	>20 mNm		>15 mNm
Hour shaft torque	>20 mNm		>20 mNm
24-hour shaft torque	-		>30 mNm
Hand weight	Typically 70 g, max. 140 g (well-balanced)		

HEADQUARTERS / PRODUCTION

MOSER-BAER AG
Spitalstrasse 7, CH-3454 Sumiswald
Tel. +41 34 432 46 46 / Fax +41 34 432 46 99
moserbaer@mobatime.com / www.mobatime.com

SALES WORLDWIDE

MOSER-BAER SA EXPORT DIVISION
19 ch. du Champ-des-Filles, CH-1228 Plan-les-Ouates
Tel. +41 22 884 96 11 / Fax + 41 22 884 96 90
export@mobatime.com / www.mobatime.com

SALES SWITZERLAND

MOBATIME AG
Stettbachstrasse 5, CH-8600 Dübendorf
Tel. +41 44 802 75 75 / Fax +41 44 802 75 65
info-d@mobatime.ch / www.mobatime.ch

MOBATIME SA
En Budron H 20, CH-1052 Le Mont-sur-Lausanne
Tél. +41 21 654 33 50 / Fax +41 21 654 33 69
info-f@mobatime.ch / www.mobatime.ch

SALES GERMANY, AUSTRIA

BÜRK MOBATIME GmbH
Postfach 3760, D-78026 VS-Schwenningen
Steinkirchring 46, D-78056 VS-Schwenningen
Tel. +49 7720 8535 0 / Fax +49 7720 8535 11
buerk@buerk-mobatime.de / www.buerk-mobatime.de

